

Item Number	Document Number	Title	Material	Quantity
1	TD-1152-9063	KL	(None)	1
2	TD-1152-9074	EMR CHASSIS	(None)	1
3	TD-1152-9038	DATUM FEATURE (FOR CONSTRUCTION)	(None)	1

FOR INFORMATION ONLY
DRAFT - 18/08/11

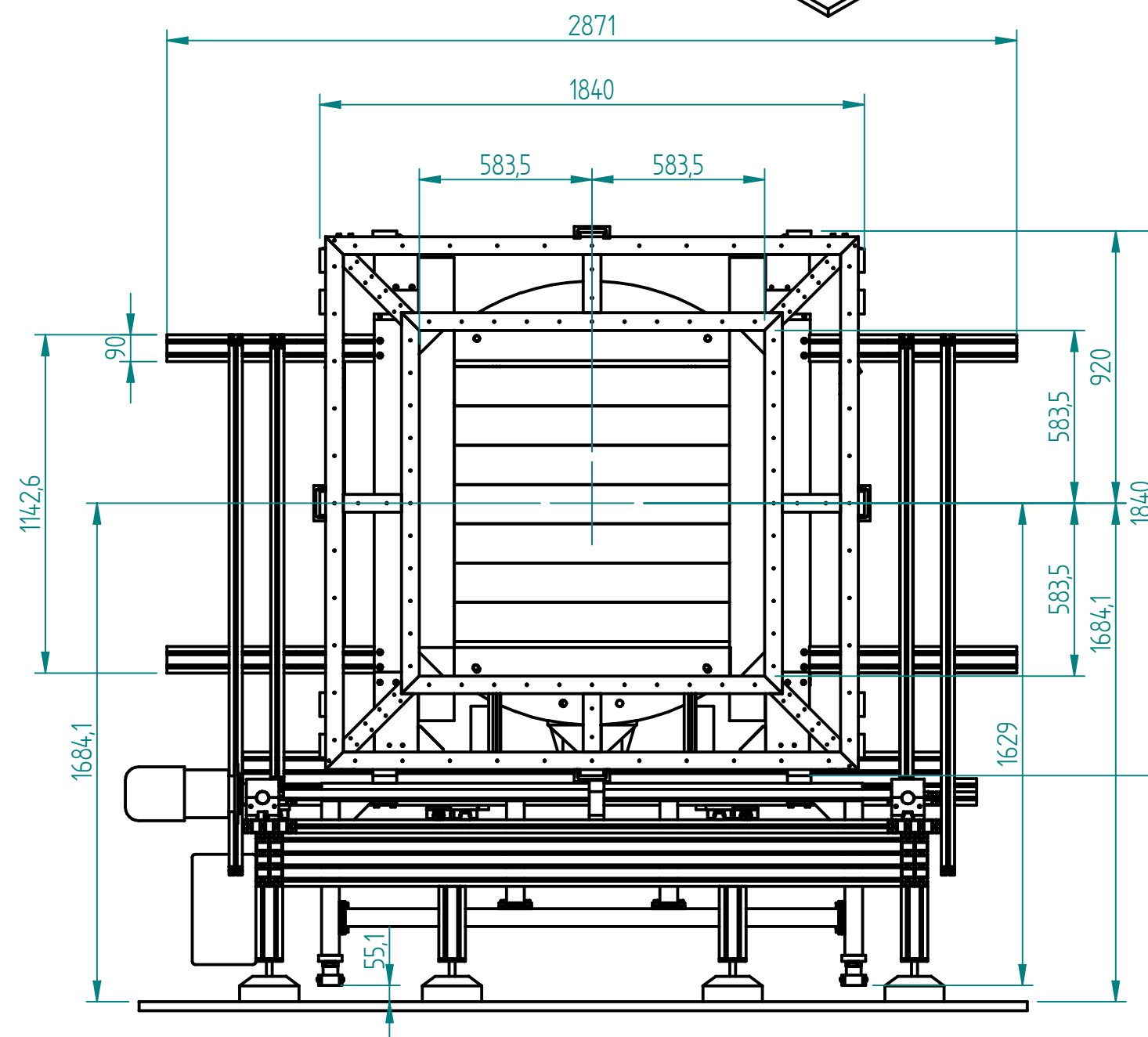
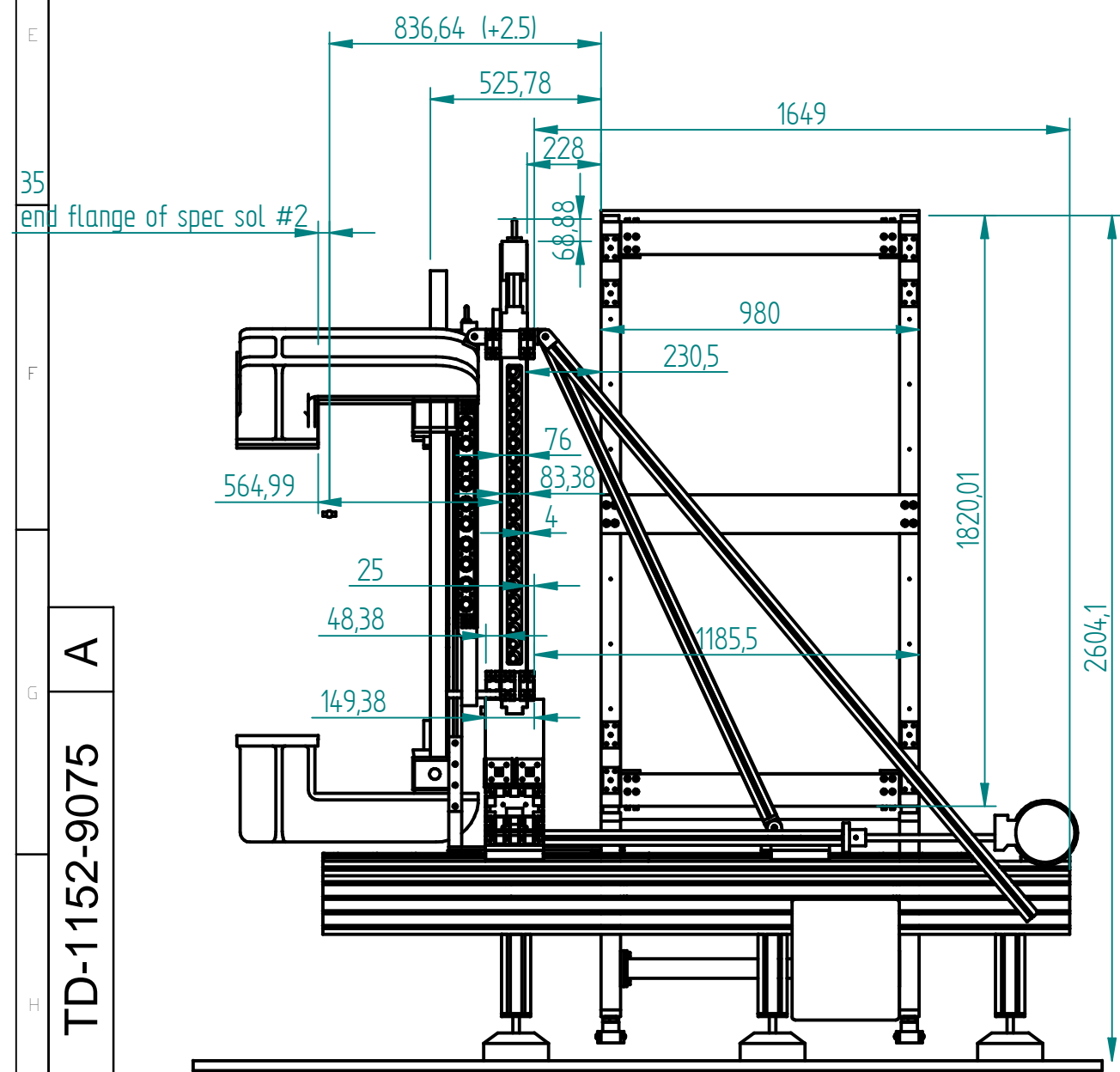
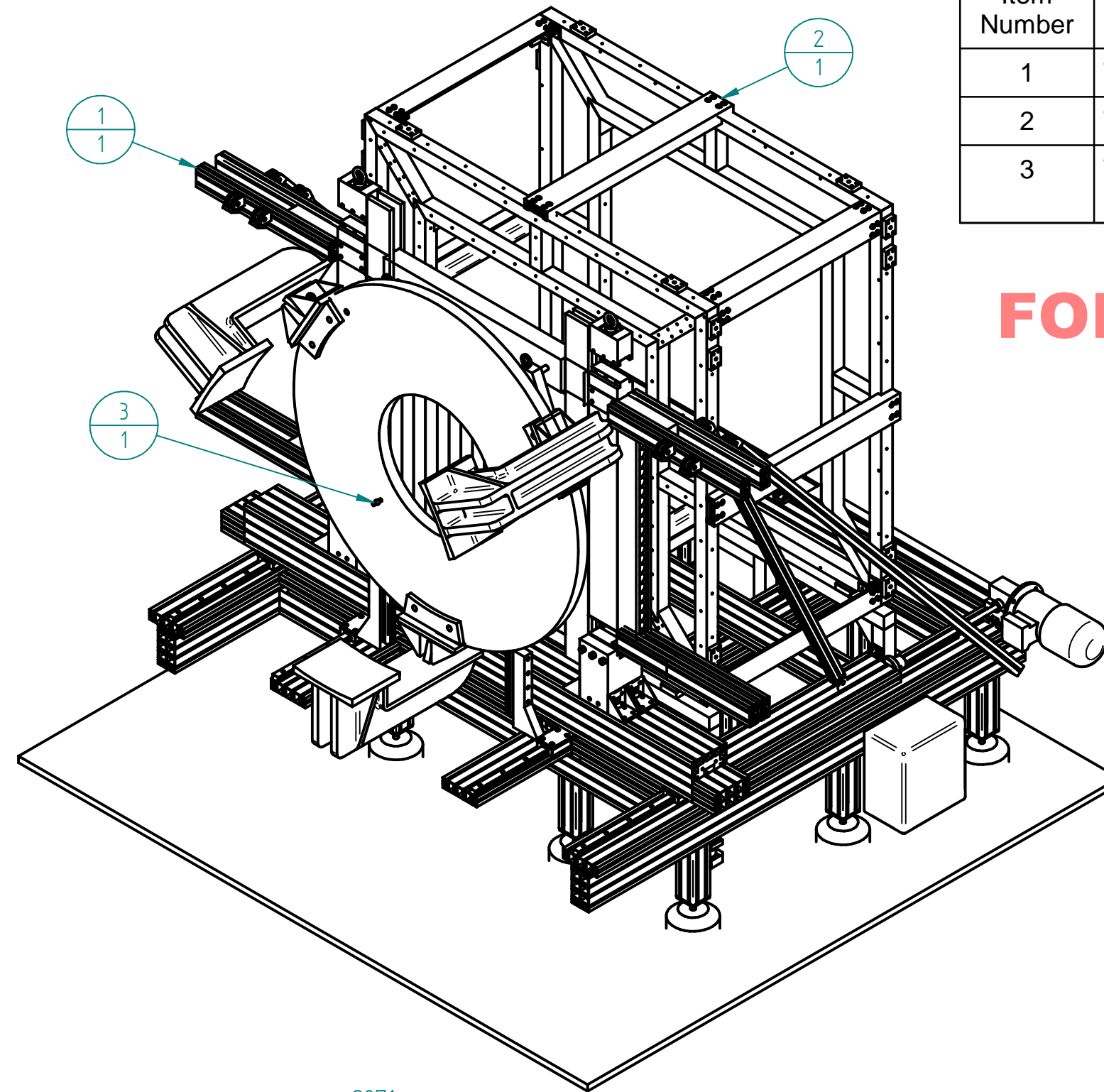
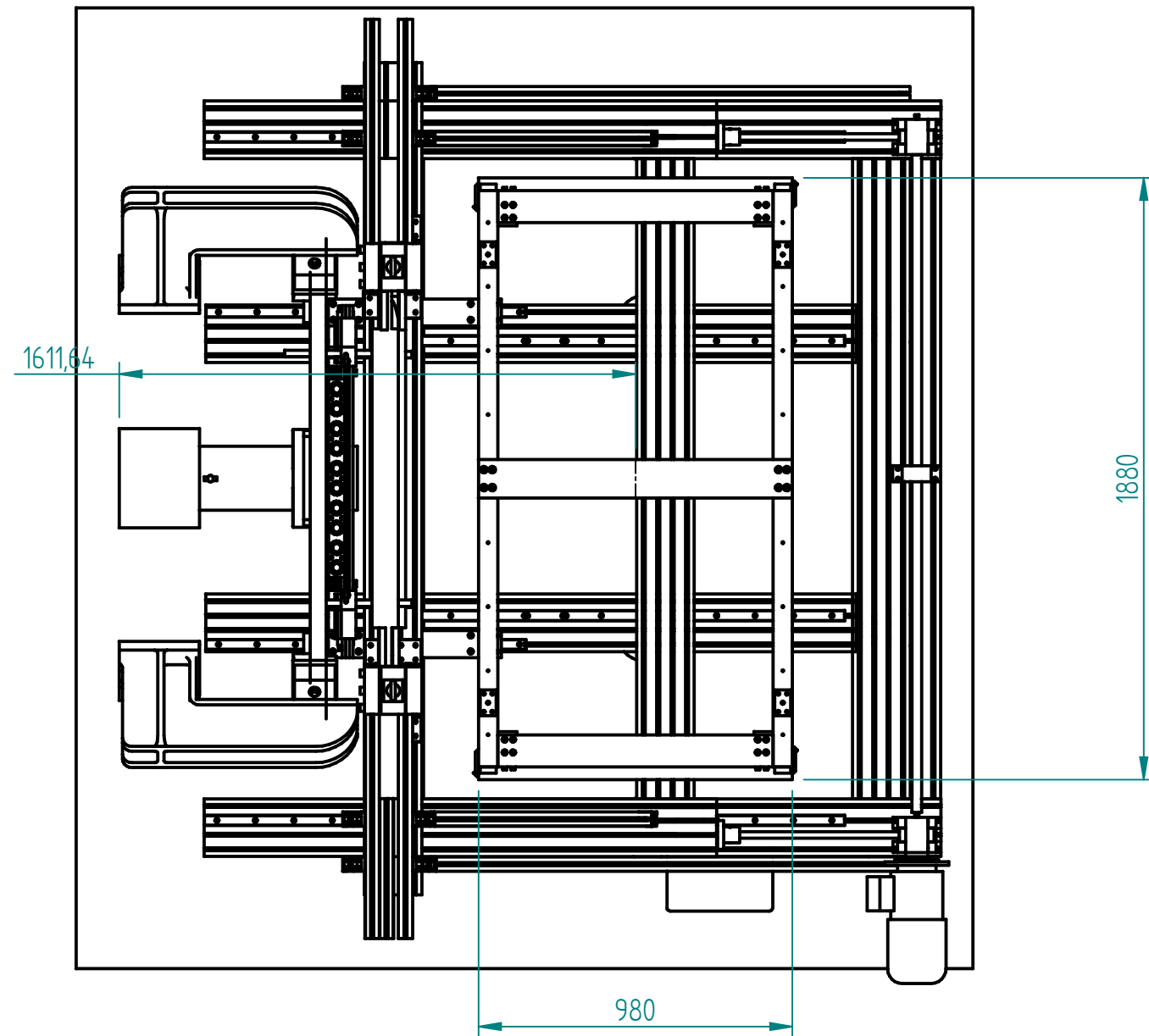

A Error: No reference		J S TARRANT Error: No reference		MANUFACTURE ONLY WHEN STATUS IS RELEASED Error: No reference		STATUS	
ISSUE	DATE APPD	MOD. No.	DRAWN BY	CHKD BY	APPD BY		
					TOLERANCES UNLESS STATED LINEAR ± N/A ANGULAR ± N/A		SURFACE TEXTURE N/A μm
DRAWING CONFORMS TO BS 8888 TOLERANCING ISO 8015			MATERIAL & SPEC. MASS 0.000 kg		FINISH N/A REMOVE ALL BURRS		
DIMENSIONS IN mm UNLESS STATED							
PROJECTS & MECHANICAL ENGINEERING GROUP (RAL)				USED ON			
HARWELL SCIENCE & INNOVATION CAMPUS, RUTHERFORD APPLETON LABORATORY, CHILTON, OXON, OX11 0QX							
KL & EMR ASSEMBLY MICE INTEGRATION ENGINEERING							
MICE TDR126							
A2		TD-1152-9075			SHEET		1 of 1