

R9 Progress (inc. Rack and Compressors)

Melissa George

7/5/13

Summary

- R9 Model
- Rack Model
- Compressor Model
- Next Steps

Apologies for the slow progress. This is due to me having ~4 weeks of other commitments.

R9 Coordinate System

Originally picked to match that used by Vicky

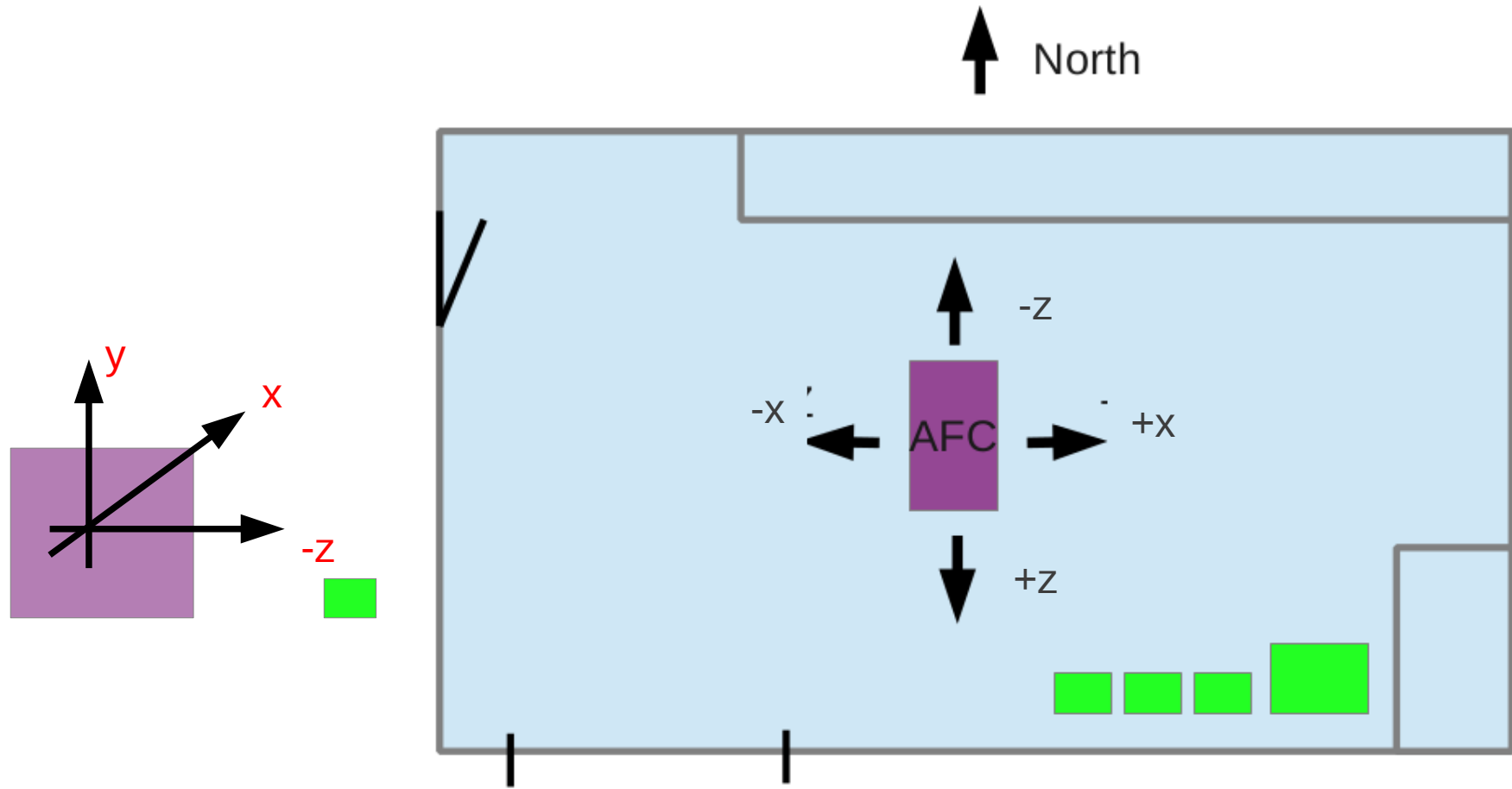

Figure: Rough schematic of the R9 hall. Green boxes are rack (large) compressors.

New R9 Coordinate System

Z-ive through AFC toward door, x +ive to North (inner) wall

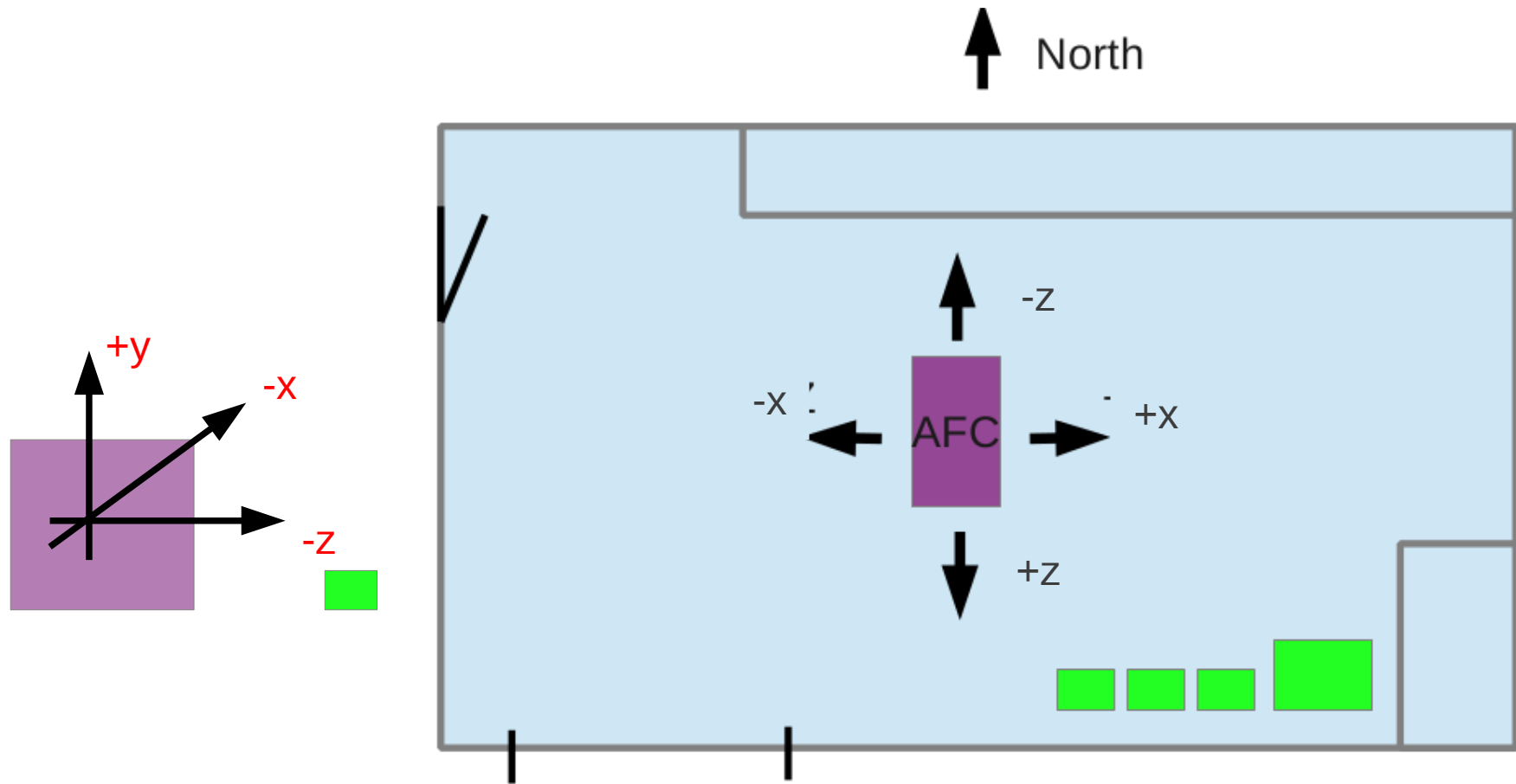

Figure: Rough schematic of the R9 hall. Green boxes are rack (large) compressors.

R9 Coordinate System

Picked to match that used by Vicky (Ian and Cileste)



Changed to make +z through AFC (west), to make it more logical. Objections???

Figure: Rough schematic of the R9 hall. Green boxes are rack (large) compressors.

R9 Dimensions

~ +/- 5cm error

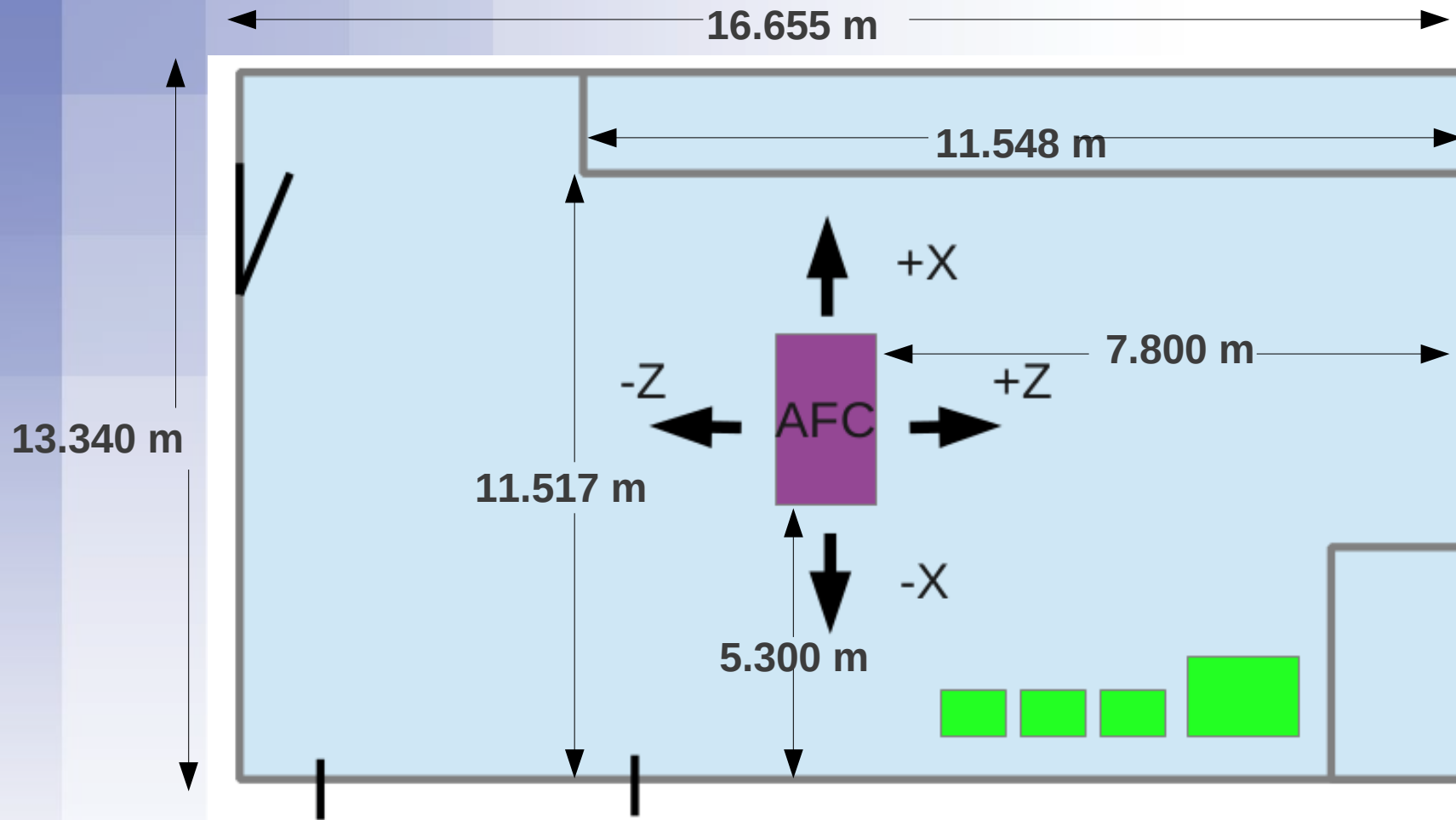

R9 Height = 9.000 m

Measurements at RAL

- Had a look at Ian's measurements with an uncalibrated probe measuring $|z|$.
- Made some measurements as above in the region of compressors and rack.
 - No metal found in floor at this very rough first pass.

R9 Model readiness

- V0 of Model of room complete
 - No Walls
 - AFC is chosen by the user to be in flip or normal mode
 - Metal in floor and storeroom not included
- Rack and compressor models can be added in various levels of detail to the R9 code as external models
- Currently working to find the meshing sweet spot.....

Here's Why

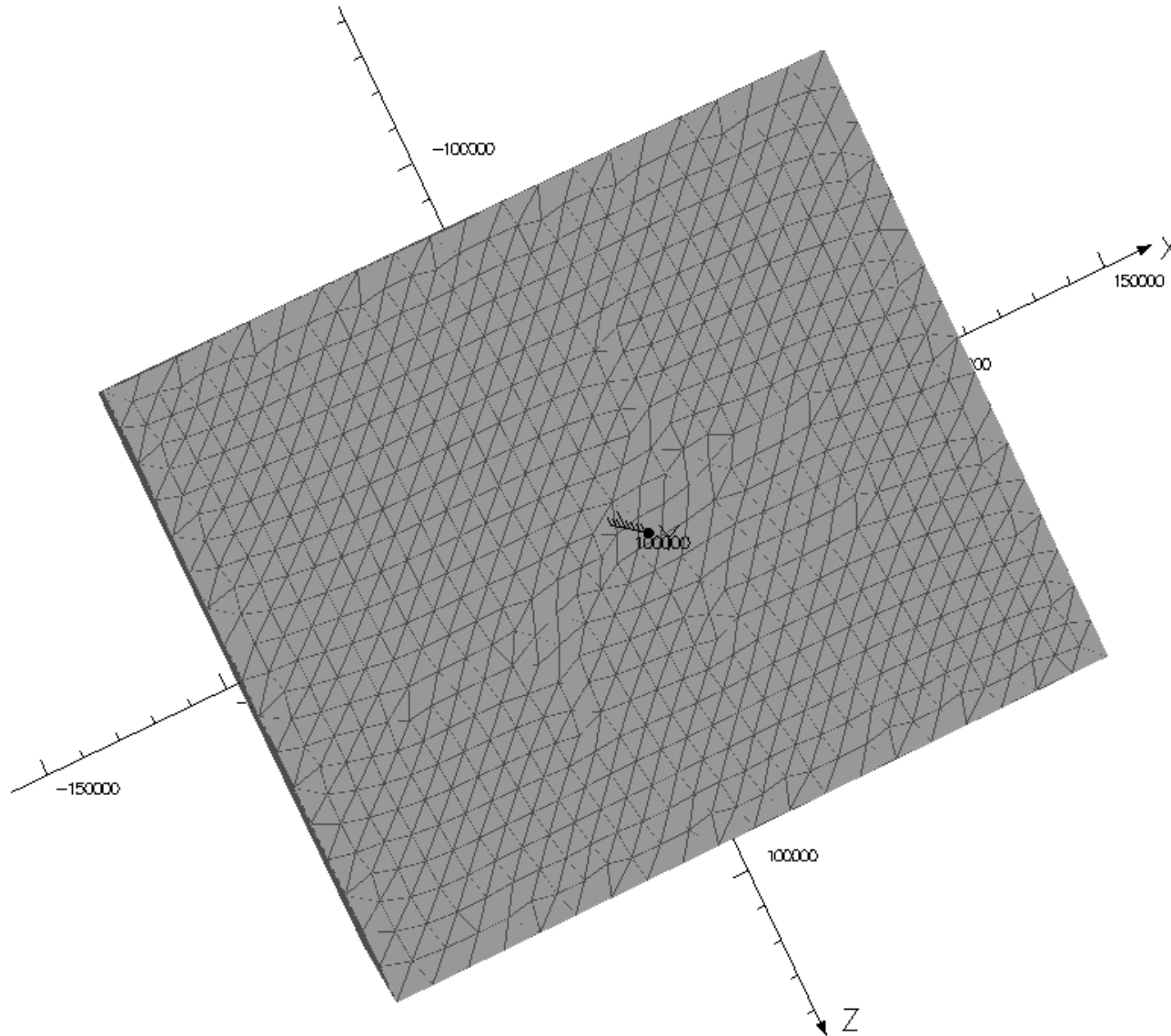

Rack Model – As Before

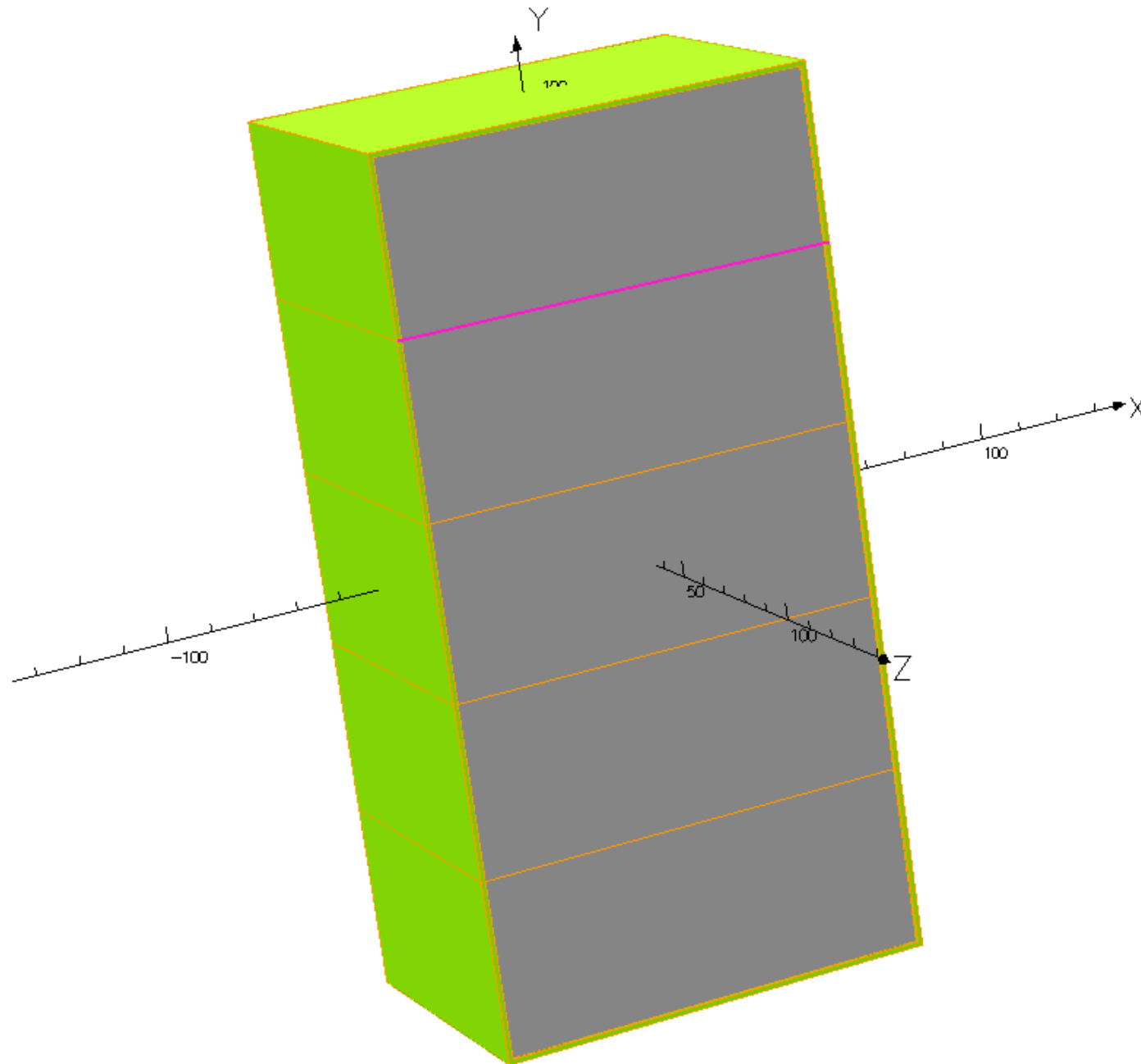

Compressor Model

- At the moment it looks much like the rack model, but it will look like this ->

Finer meshing will be used wherever you see a line in this design.

Air blocks, just for ease of understanding

Copper again for understanding

Mild Steel

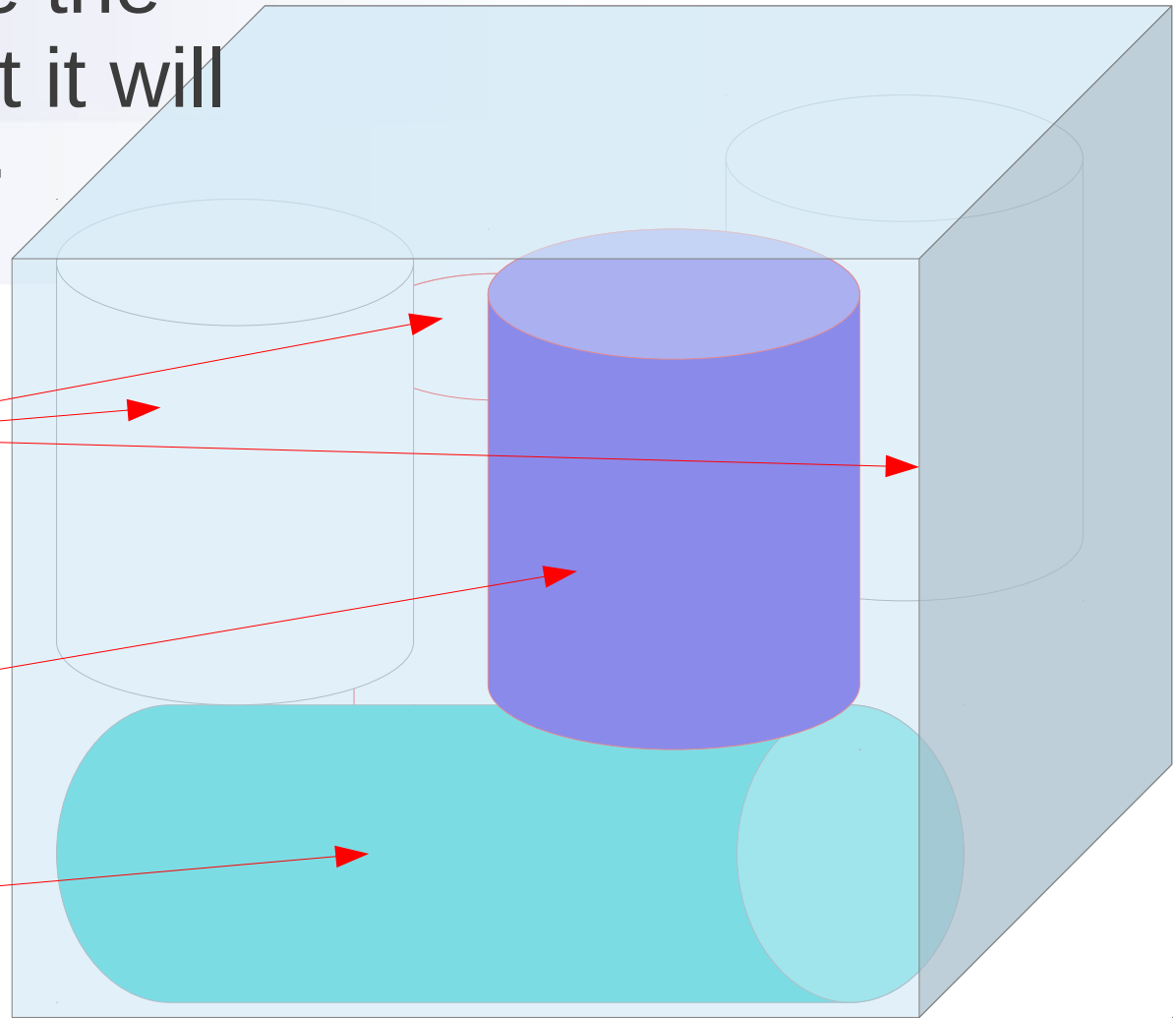

Compressor Model

- At the moment it looks much like the rack model, but it will look like this ->

Finer meshing will be used wherever you see a line in this design.

Air blocks, just for ease of understanding

Copper again for understanding

Mild Steel

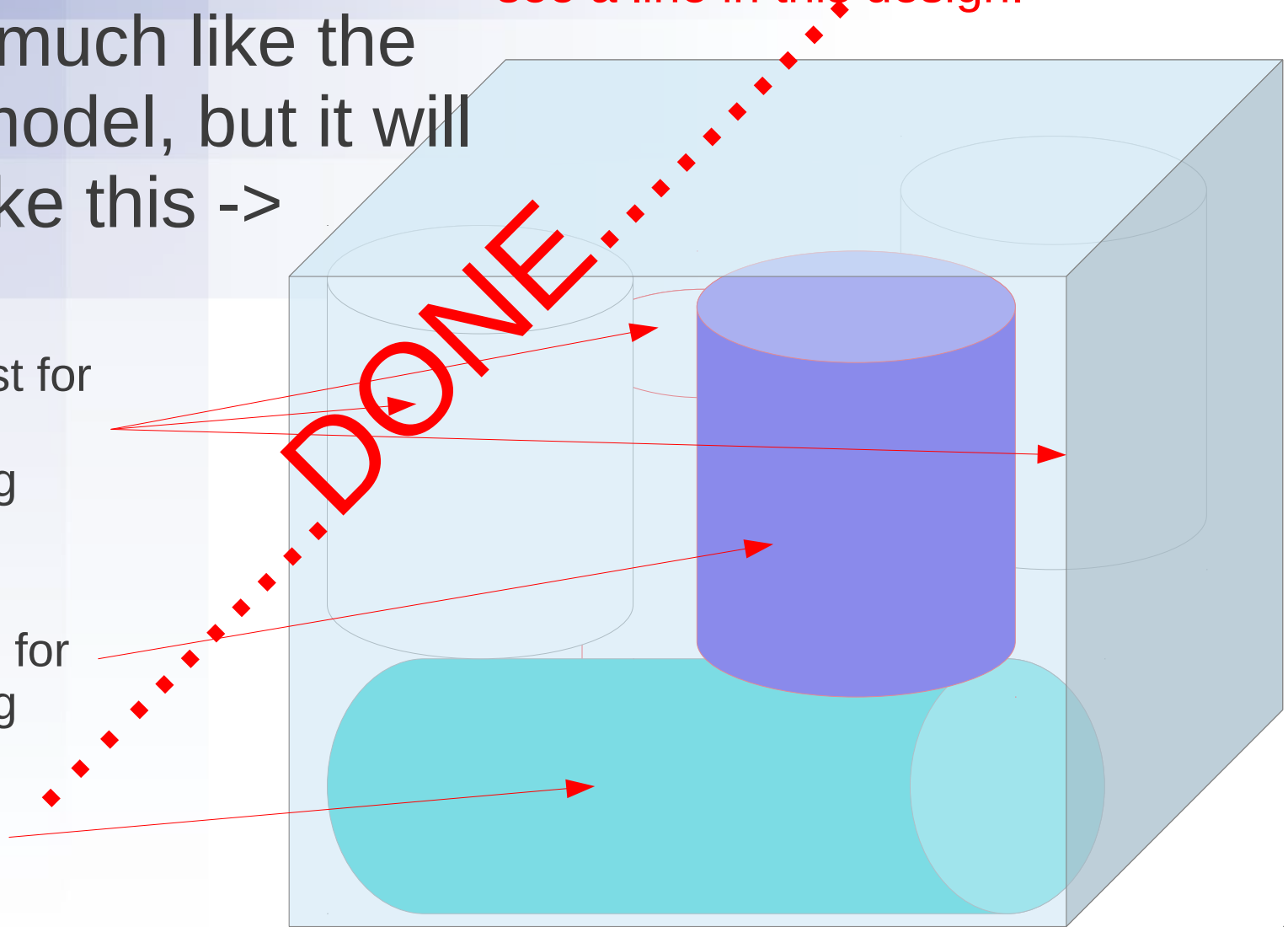

Compressor Model

30/Apr/2013 11:44:14

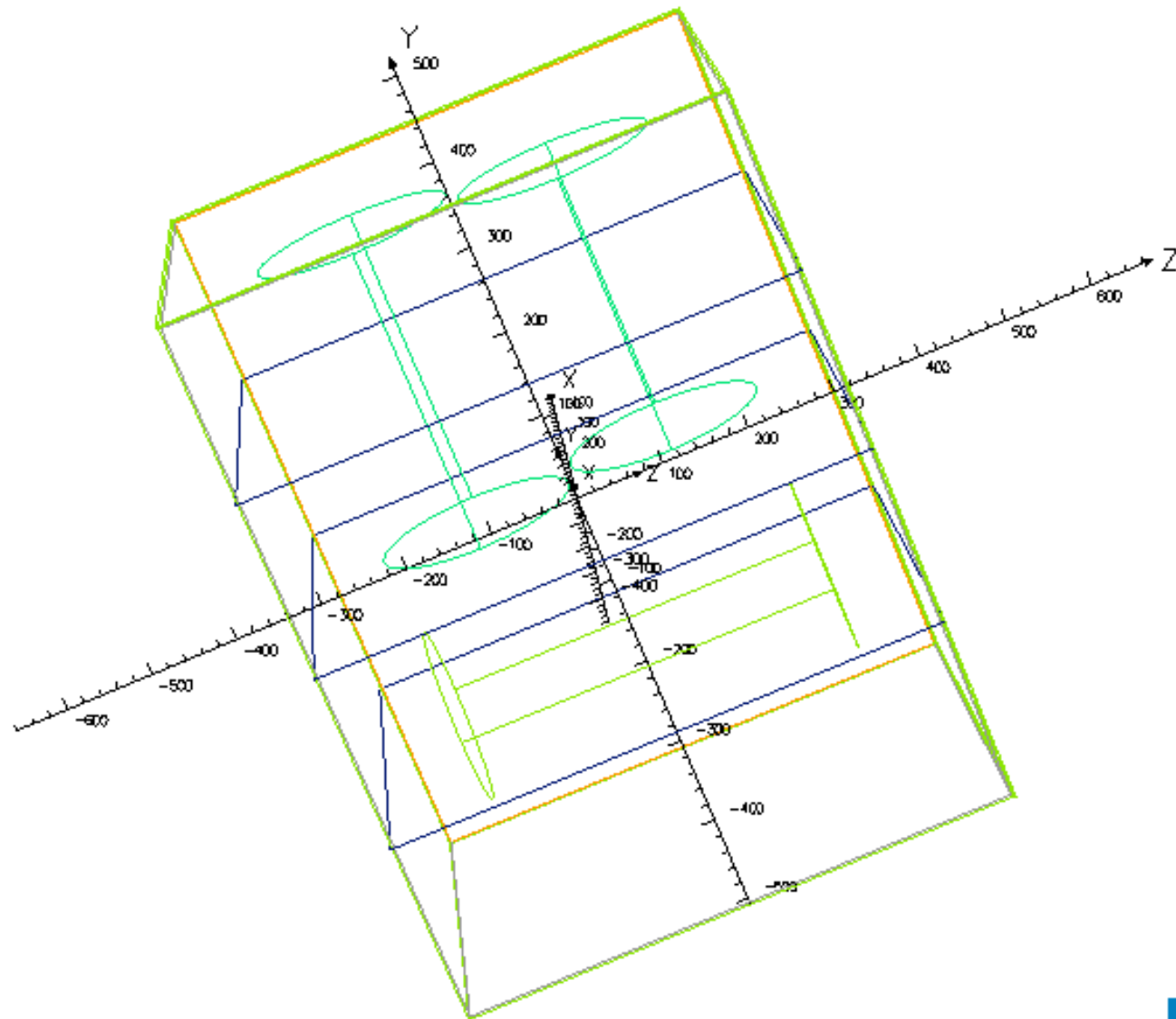

Compressor Model - Next

- There are some extra areas of mild steel that may or may not be modelled in a second round depending upon physics case. These areas are shown in red.
- Once meshing has been improved the model will be run with and without additional iron to judge the benefit of including it.

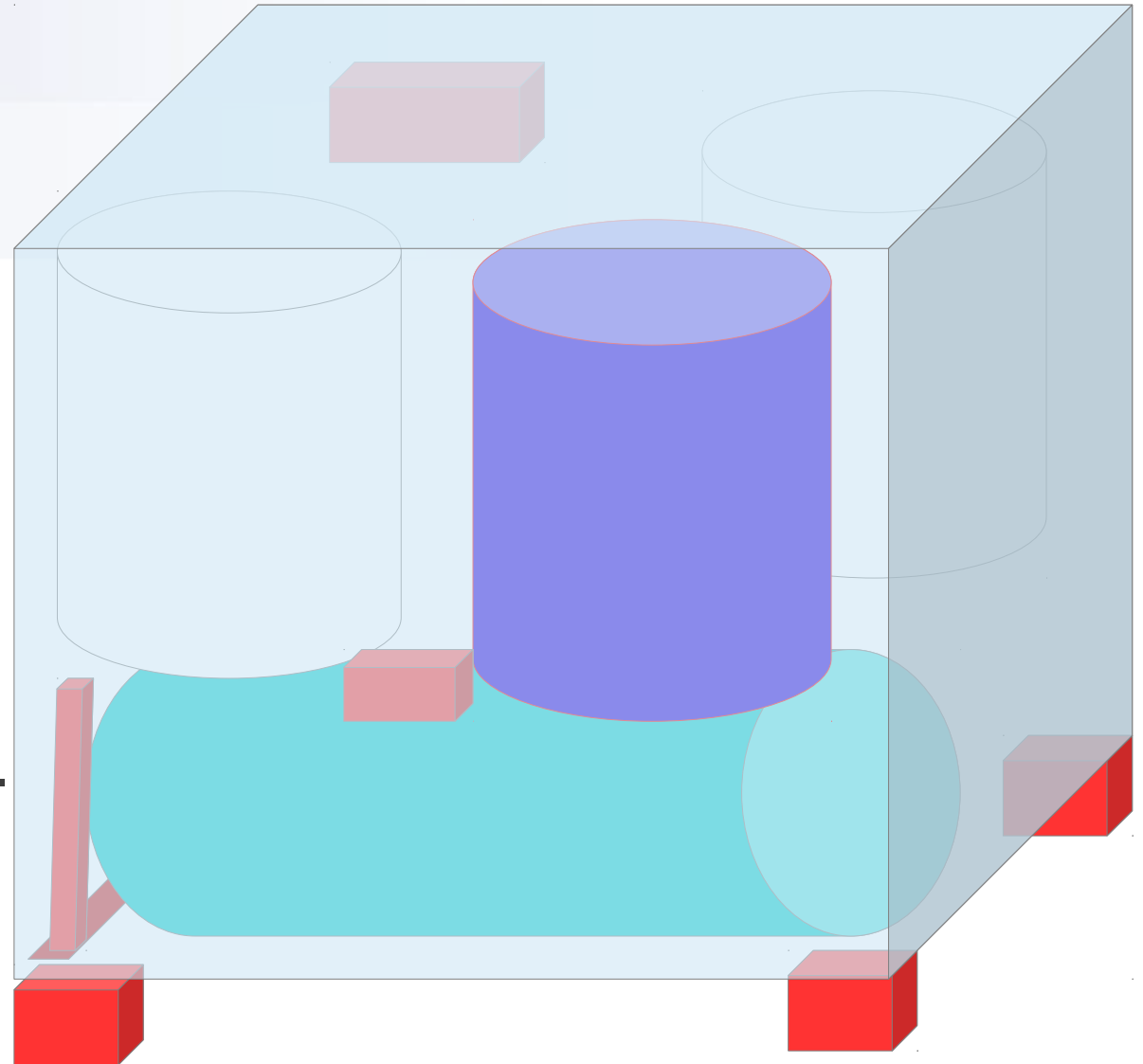

Next Steps

- Include walls in R9 model.
- Improve model meshing.
- Rack model input.
- Compressor model input.
- Cileste can begin comparisons with data.
- Implement joists (and workshop) in model.
- More comparisons.
- Develop Rack and Compressor models as sub-models to hall model.